



# WORKSHOP MANUAL

## 12v Electrical

### Index Ref No:

#### Introduction

#### 1

#### PIN LOCATIONS

- 1.1.0 PDU (2005 -06 Full Range )
- 1.2.0 PDU (Senator 6 & Pageant 7)
- 1.3.0 Control Panel Connectors
- 1.3.1 Control Panel Connectors (Ranger 6 & Pageant 7)
- 1.4.0 ATC / TRACKER Connectors
- 1.5.0 Various Connectors
- 1.6.0 Radio Connectors
- 1.7.0 12N / 12S / "Yaegar" Continental Connector
- 1.8.0 "Yaegar" Cable Connectors To PDU (2008 on)

#### 2

#### WIRING DIAGRAMS

- 2.1.0 ATC
- 2.2.0 Tracker
- 2.3.0 Water Pump (Discovery / Ranger / Pageant 5)
- 2.3.1 Water Pump (Ranger 6)
- 2.4.0 Water Pump (Pageant 6)
- 2.4.1 Water Pump (Pageant 7)
- 2.5.0 Water Pump (Senator 5)
- 2.5.1 Water Pump (Senator 6)
- 2.6.0 Appliances (2005 -06 Full Range )
- 2.6.1 Appliances (Senator 6)
- 2.6.2 Appliances (Ranger 6)
- 2.6.3 Appliances (Pageant 7)
- 2.7.0 Rear Road Lights

#### 3

#### INFORMATION & SETTING

- 3.1.0 PIR Coding ( Senator 6)
- 3.2.0 Key Fob Programming (Senator 6)
- 3.3.0 ATC Testing

#### 4

#### DIAGNOSTICS & TROUBLESHOOTING

- 4.1.0 Loss Of 12v Diagnostic Flow Chart
- 4.2.0 Ultra Store Diagnostic Flow Chart
- 4.2.1 Ultra Heat Diagnostic Flow Chart
- 4.3.0 Troubleshooting On Discovery
- 4.4.0 Troubleshooting On Ranger
- 4.5.0 Troubleshooting On Pageant
- 4.6.0 Troubleshooting On Senator
- 4.7.0 Troubleshooting On ATC

Dealer Feed Back & Introduction To Troubleshooting



# INTRODUCTION

This manual has been designed to assist in fault finding & rectification of 12v electrical problems that may occur. It should be used as a guide as there may have been certain changes made on or around the manufacturing date. Changes may also occur with no prior notice, this may be due to our suppliers & is sometimes out of our control.

To understand the abbreviations contained within this manual please refer to the tables & charts below.

Please also note that multiplug connections have been drawn from the rear on wire entry to connector, however PDU pin locations have been drawn how you see them from the out side.

## Steps to remember in fault finding and self diagnostics

- 1 Something new doesn't always mean it's not faulty (especially batteries)
- 2 Check the obvious i.e. battery condition & voltage / fuses / sufficient gas in bottles.
- 3 Make sure the fault exists.
- 4 Intermittent faults, Start simply & don't over complicate it.
- 5 Always make your own assessment and do not be mislead by someone else's diagnostic decision.
- 6 Non standard & added fittings can also effect the behaviour of the electrical system.

### **COLOUR CODING**

RD	Red
WT	White
GR	Green
BL	Blue
BR	Brown
BK	Black
OR	Orange
YE	Yellow
PR	Purple
GY	Grey

### **ABBREVIATIONS**

PDU - Power Distribution Unit
ATC - AL-KO Trailer Control
IGN - Ignition
PCB - Printed Circuit Board
LED - Light Emitting Diode

If you find any information missing or incorrect please bring it to our attention as this is your manual as much as it ours, we are always looking for ways to improve our service to you.

Bailey's policy is commitment to customer care.



## **PIN LOCATIONS**

### **INDEX**

# **1**



# PIN LOCATIONS

Index Ref: 1.1.0

PDU PIN LOCATION

Nov-07

Discovery / Ranger 5 / Senator 5 / Pageant 6

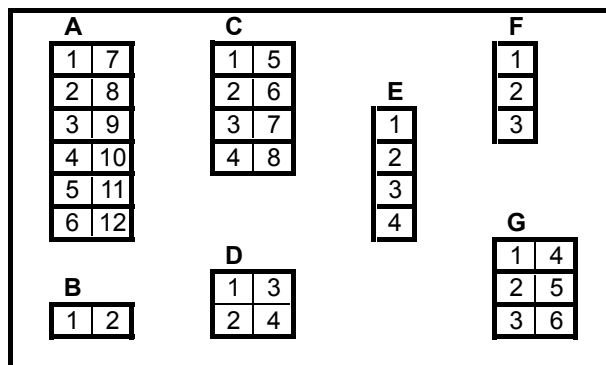

## Connector

Source	Colour
<b>A</b>	
1 Lights Relay In PDU	OR
2 Lighting Circuit	RD/OR
3 Water Pump (P/Potti Sen 5 )	GR/BL (PR)
4 Radio (Senator)	YE
5 Lighting Circuit	RD/OR
6 Main Switch (Control Panel)	GR/RD
7 Aux 12v Socket	YE
8 Ceiling Fan	BL/RD
9 Lighting Circuit	RD/OR
10 Water Heater	BL
11 Lighting Circuit	RD/OR
12 Return From Master Switch	RD
<b>B</b>	
1 Van Battery +	RD
2 Van Battery -	BK
<b>C</b>	
1 Earth	WT
2 Earth	WT
3 Earth	WT
4 Earth	WT
5 Earth	WT
6 Earth	WT
7 Earth	WT
8 Fridge Earth (From Car Power)	BK

## Connector

Source	Colour
<b>D</b>	
1 Perm Car Power	GR
2 Fridge Pos From Car	RD
3 Neg From Car	WT
4 Fridge Neg From Car	BK
<b>E</b>	
1 Fridge Ign (Senator)	RD
2 Fire Fan	GY
3 Oven / Hob Ign	BK
4 Fridge 12v (From Car Power)	RD
<b>F</b> Series 5 senator only	
1 12v Car Power To Alarm	GR
2 Neg To Alarm	WT
3 Pos To Alarm	BL
<b>G</b>	
1 Earth	WT
2 Earth	WT
3 Earth	WT
4 Earth	WT
5 Earth	WT
6 Earth	WT



# PIN LOCATIONS

Index Ref: 1.2.0

## PDU PIN LOCATIONS

Nov-07

### Ranger 6 / Senator 6 / Pageant 7

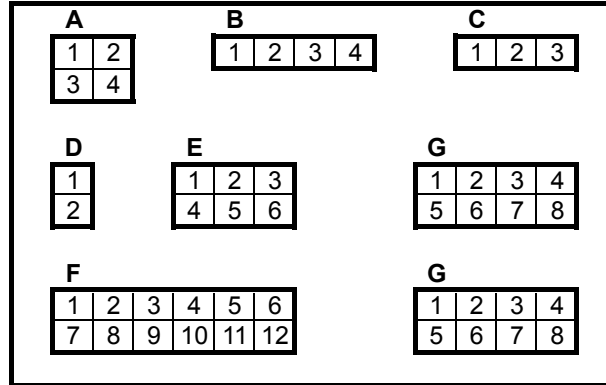

<u>Connector</u>		<u>Connector</u>	
Source	Colour	Source	Colour
<b>A</b>		<b>F</b>	
1 Lighting Circuit	GR/BK	1 Aux 12v (spare)	
2 Lighting Circuit	BL/BR	2 Aux 12v	YE
3 Lighting Circuit	GR/BK	3 Omni Vent	BL/RD
4 Lighting Circuit	BL/BR	4 Water Heater	BL
<b>B</b>		5 Tracker 12v Feed	BK/YE
1 Fridge 12v (From Car Power)	RD/OR	6 Return From Con Panel	RD
2 Oven Ign	OR	7 Aux 12v (spare)	
3 Fire Fan	GR/OR	8 Aux 12v	YE
4 Fridge Ign	GR	9 Porta Potti / Water Pump	PR
<b>C</b>		10 Radio / Booster	GR/BL
1 Float Switch Pump	BL	11 Lights Rtn From Con Panel	YE
2 Control Panel	BL/WT	12 Feed To Con Panel	GR/RD
3 Water Pump	GR/BR		
<b>D</b>		<b>G x2</b>	
1 Bat Negative	BK	1 Earth	WT
2 Bat Live	RD	2 Earth	WT
<b>E</b>		3 Earth	WT
		4 Earth	WT
1 Ign Fridge 12v +	RD	5 Earth	WT
2 Perm 12v car +	GR	6 Earth	WT
3 ATC 12v Feed	GR	7 Earth	WT
4 Fridge 12v Earth	BK	8 Fridge Earth (From Car Power)	BK
5 Perm 12v car Earth	WT		
6 ATC 12v Earth	WT		

July 2008 on

RD/BR

BL/BR

GR

GR/WT

BL/WT

WT



# PIN LOCATIONS

Index Ref: 1.3.0

CONTROL PANELS

Dec-07

## Discovery / Ranger 5 / Pageant 5 & 6

### 8 Pin Multiplug To Control Panel

1	2	3	4
5	6	7	8

- |   |                                    |       |
|---|------------------------------------|-------|
| 1 | Light Switch Return To PDU         | OR    |
| 2 | Pump Feed To Switch                | GR/BL |
| 3 | Main Feed Return To PDU For Relays | RD    |
| 4 |                                    |       |
| 5 | Pump Signal For LED                | RD/WT |
| 6 | Positive Feed To Pump              | GR/BR |
| 7 | Main Feed To Master Switch         | GR/RD |
| 8 | Earth Wires                        | WT    |

## Senator Series 5

### 12 Pin Multiplug To Control Panel

1	2	3	4	5	6
7	8	9	10	11	12

- |    |                                    |       |
|----|------------------------------------|-------|
| 1  | Awning Light                       | GR/OR |
| 2  |                                    |       |
| 3  | Light Switch Return To PDU         | OR    |
| 4  | Pump Feed To Switch                | GR/BL |
| 5  | Main Feed Return To PDU For Relays | RD    |
| 6  |                                    |       |
| 7  | Gas Box Light                      | BR    |
| 8  | Return For Tank Level Light        | BK/WT |
| 9  | Pump Signal For LED                | RD/WT |
| 10 | Positive Feed To Pump              | GR/BR |
| 11 | Main Feed To Master Switch         | GR/RD |
| 12 | Earth Wires                        | WT    |

## Senator Series 6

### 12 Pin Multiplug To Control Panel

1	2	3	4	5	6
7	8	9	10	11	12

- |    |                                    |         |
|----|------------------------------------|---------|
| 1  | Pump Fill (Returns To PDU Relay)   | BR + BL |
| 2  |                                    |         |
| 3  | Light Switch Return To PDU         | YE      |
| 4  | Pump Feed To Switch                | PR      |
| 5  | Main Feed Return To PDU For Relays | RD      |
| 6  |                                    |         |
| 7  | Gas Box Light                      | OR/WT   |
| 8  | Return For Tank Level Light        | GR      |
| 9  | Pump Signal For LED                | RD/WT   |
| 10 | Pump Run (Direct Feed To Pump)     | GR/BR   |
| 11 | Main Feed To Master Switch         | GR/RD   |
| 12 | Earth Wires                        | WT      |



# PIN LOCATION

Index Ref: 1.3.1

CONTROL PANELS

Jun-08

## Ranger Series 6 & GT60

8 Pin Multiplug To Control Panel

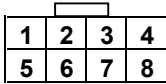

- |   |   |               |
|---|---|---------------|
| 1 | Light Switch Return To PDU              | YE            |
| 2 | Pump Feed To Switch                     | PR            |
| 3 | Main Feed Return To PDU For Relays      | RD            |
| 4 | LED Neg Return From The Pressure Switch | BK            |
| 5 | Pump Signal For LED                     | RD/WT         |
| 6 | Positive Feed To Pump                   | GR/BR & RD/WT |
| 7 | Main Feed To Master Switch              | RD/WT         |
| 8 | Earth Wires                             | WT            |

## Pageant Series 7

Up to July 2008

8 Pin Multiplug To Control Panel

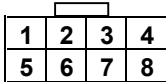

- |   |                                    |       |
|---|------------------------------------|-------|
| 1 | Light Switch Return To PDU         | YE    |
| 2 | Pump Feed To Switch                | PR    |
| 3 | Main Feed Return To PDU For Relays | RD    |
| 4 |                                    |       |
| 5 | Pump Signal For LED                | RD/WT |
| 6 | Positive Feed To Pump              | GR/BR |
| 7 | Main Feed To Master Switch         | GR/RD |
| 8 | Earth Wires                        | WT    |

8 Pin Multiplug To Control Panel

From July 2008

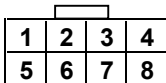

- |   |                                    |               |
|---|------------------------------------|---------------|
| 1 | Light Switch Return To PDU         | YE            |
| 2 | Pump Feed To Switch                | PR            |
| 3 | Main Feed Return To PDU For Relays | RD            |
| 4 | Neg Link For Pump LED              | BK            |
| 5 | Pump Signal For LED                | RD/WT         |
| 6 | Positive Feed To Pump              | GR/BR & RD/WT |
| 7 | Main Feed To Master Switch         | RD/WT         |
| 8 | Earth Wires                        | WT            |



# PIN LOCATIONS

Index Ref: 1.4.0

ATC & TRACKER

Dec-07

## Senator 6 / Pageant 7 & Optional Fitment

### ATC

#### 6 Pin Multiplug to PDU

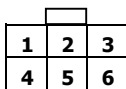

- |   |                            |    |
|---|----------------------------|----|
| 1 | Earth to ATC Unit          | WT |
| 2 | Earth From Car 12s         | WT |
| 3 | Earth From Car 12s         | BK |
| 4 | Feed To ATC Unit           | GR |
| 5 | Feed From Car 12s          | GR |
| 6 | Fridge feed From 12s (Ign) | RD |

#### 14 Pin Multiplug to ATC actuator

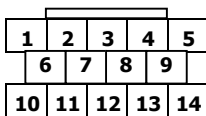

- |   |                               |    |    |                       |
|---|-------------------------------|----|----|-----------------------|
| 1 | Earth From PDU                | WT | 8  |                       |
| 2 | Earth From PDU                | WT | 9  |                       |
| 3 | Earth To LED On "A" Frame     | WT | 10 | Live Feed From PDU GR |
| 4 |                               |    | 11 | Live Feed From PDU GR |
| 5 | Live Feed To Led On "A" Frame | RD | 12 |                       |
| 6 |                               |    | 13 |                       |
| 7 |                               |    | 14 |                       |

#### 2 Pin Multiplug to LED



- |   |                         |    |
|---|-------------------------|----|
| 1 | Live feed from ATC unit | RD |
| 2 | Earth from ATC unit     | WT |

### TRACKER

#### 6 Pin Multiplug to tracker unit

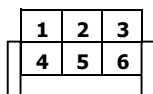

- |   |               |       |
|---|---------------|-------|
| 1 | Antenna       | BR    |
| 2 | Siren Earth   | BK    |
| 3 | Siren Feed    | GR    |
| 4 | Empty         |       |
| 5 | Tracker Earth | WT    |
| 6 | Tracker Feed  | BK/YE |

#### 2 Pin Multiplug to siren



- |   |             |    |
|---|-------------|----|
| 1 | Siren feed  | GR |
| 2 | Siren earth | BK |





# PIN LOCATION

Index Ref: 1.5.0

Various Connectors

Feb-08

## Through Out The Range

### Fridge

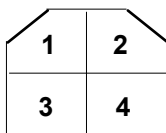

1	Earth	WT
2	12v Feed from PDU	GR
3	Car Power	BK
4	Car Power	RD/OR

### Lighting

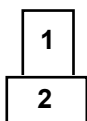

1	12v Feed from PDU (Dependant of lighting circuit)	→ 2007 →	RD/OR
2	Earth	→ 2007 →	GR/BK & BL/BR WT

### Omni Vent

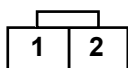

1	Earth	WT
2	12v Feed from PDU	BL/RD

### Porta Potti



1	12v Feed from PDU	PR
2	Earth	WT

### Water Pump (Whale inboard pump)

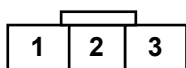

1	Earth	WT
2	Signal return to LED in control panel	RD/WT
3	12 v Feed from control panel	GR/BR

### Rear Lights

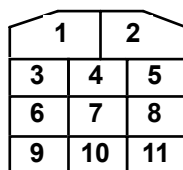

1	Earth	WT	6	O/S indicator	GR
2	Earth	WT	7	Fog light	BL
3	Earth	WT	8	Stop light	RD
4	Reversing light	YE/BK	9	N/S tail lights	BK
5	Earth	WT	10	O/S tail lights	BR
			11	N/S indicator	YE

### Tank Floats (Senator Series 6)

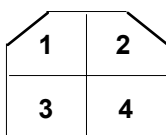

1	Earth	WT	Bottom Float
2	Earth return to "LED"	GY	
3	12v Feed	BL	Top Float
4	Return to "PDU"	BL	



# PIN LOCATIONS

Index Ref: 1.6.0

RADIO CONNECTIONS

Dec-07

## Pageant 6 / Senator 5

1	2	3
4	5	6

Radio  
Loom

1	Earth	BK
2	Speaker	GR/BK
3	Speaker	PR/BK
4	12v Feed	RD & YE (two wires joined)
5	Speaker	WT
6	Speaker	GY

3	2	1
6	5	4

Harness  
Side

1	Earth	WT
2	Speaker	GY
3	Speaker	BK
4	12v Feed	YE (Pageant 6) or GR/BL (Senator 5)
5	Speaker	GY/BK
6	Speaker	BK/WT

## Senator 6 / Ranger GT60 / Pageant 7

6	5	4	3	2	1
12	11	10	9	8	7

Radio  
Loom

1	12v Feed	YE	7	12v Feed	YE
2	Speaker	GR/BK	8	Speaker	GR
3	Speaker	PR/BK	9	Speaker	PR
4	Speaker	WH/BK	10	Speaker	WH
5	Speaker	GY/BK	11	Speaker	GY
6	Earth	BK	12	12v Feed	RD

1	2	3	4	5	6
7	8	9	10	11	12

Harness  
Side

1		7			
2		8			
3		9			
4	Speaker	BK	10	Speaker	BK/WT
5	Speaker	GY	11	Speaker	GY/BK
6	Earth	WT	12	12v Feed	GR/BL

### Speaker Colouring

Purple	Rear	Not used
Grey	Front	
White	Front	
Green	Rear	Not used

Left & right on speaker control is dependant on what side the radio is fitted into the locker housing and therefore cannot be colour coded to hand.



# PIN LOCATIONS

Index Ref: 1.7.0

CAR POWER

Nov-07

## 12N / 12S & Continental Connection ("YAEGAR")

### 12N

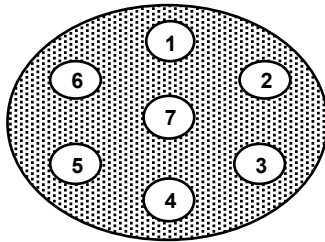

### 12S

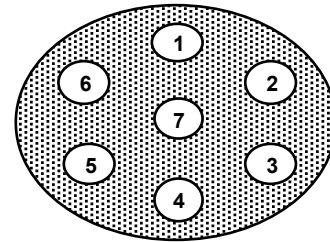

1	1/L	N/S Indicator	YE
2	2/54G	Fog Lights	BL
3	3/31	Earth	WT
4	4/R	O/S Indicator	GR
5	5/58R	O/S Side Light	BR
6	6/54	Brake Lights	RD
7	7/58L	N/S Side Light	BK

1	1/L	Reversing Light	YE
2	2/54G		
3	3/31	Negative For Lights & Charge	WT
4	4/R	Interior Lights & Charge	GR
5	5/58R		
6	6/54	Positive For Fridge	RD
7	7/58L	Negative For Fridge	BK

## Continental Connector 2008 on

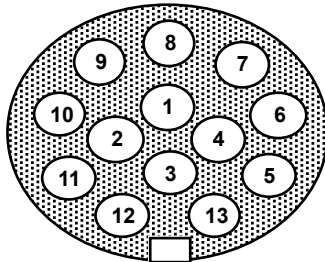

1	N/S Indicator	YE
2	Fog Lights	BL
3	Earth	WT
4	O/S Indicator	GR
5	O/S Side Light	BR
6	Brake Lights	RD
7	N/S Side Light	BK
8	Reverse Light	OR
9	12v Interior Lights	BR/BL
10	12v Fridge Supply	BR/RD
11	Earth For Pin 10	WT/GR
12	None	
13	Earth For Pin 9	WT/BL



# PIN LOCATION

Index Ref: 1.8.0

CAR POWER

Feb-08

## "YAEGAR" Cable Connectors to PDU

### 2008 on

#### 8 Pin Connector To PDU

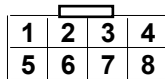

1	Reverse Light	OR
2	Fog Lights	BL
3	N/S Indicator	YE
4	O/S Indicator	GR
5	Brake Lights	RD
6	Earth	WT
7	N/S Side Light	BK
8	O/S Side Light	BR

#### 6 Pin Connector To PDU

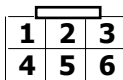

1	ATC 12v Earth	WT
2	Perm 12v car Earth	BL/WT
3	Fridge 12v Earth	GR/WT
4	ATC 12v Feed	GR
5	Perm 12v car +	BL/BR
6	Ign Fridge 12v +	RD/BR

#### 3 Pin Connector To Front Marker Lights Near PDU

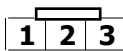

1	Earth	WT
2	N/S Side Light	BK
3	O/S Side Light	BR



# **WIRING DIAGRAMS**

**INDEX**

# **2**



# WIRING DIAGRAMS

Index Ref No: 2.1.0

ATC

Nov-07

## Senator 6 / Pageant 7

LED Light

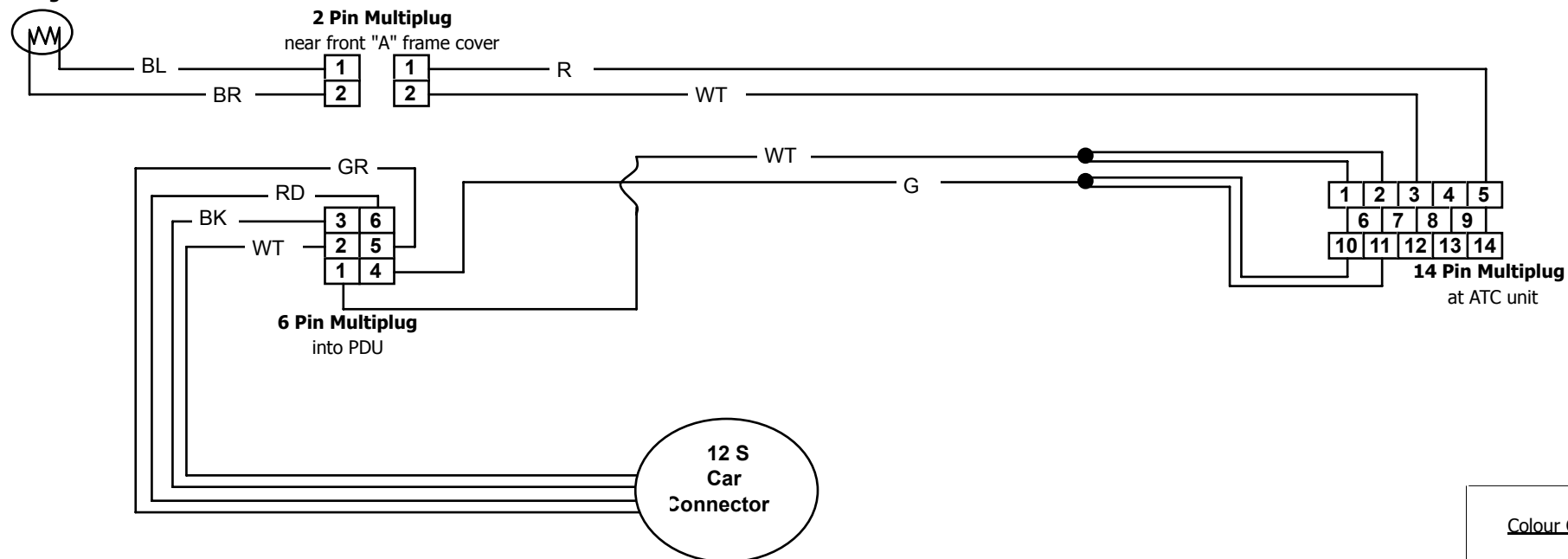

### NOTE

Pins 1 & 2 from ATC connector are joined approximately 300mm in loom  
Pins 10 & 11 from ATC connector are joined approximately 300mm in loom

### Colour Codes

RD - Red  
WT - White  
GR - Green  
BL - Blue  
BR - Brown  
BK - Black



# WIRING DIAGRAMS

Index Ref No: 2.2.0

**TRACKER**  
**Senator 6**

Nov-07

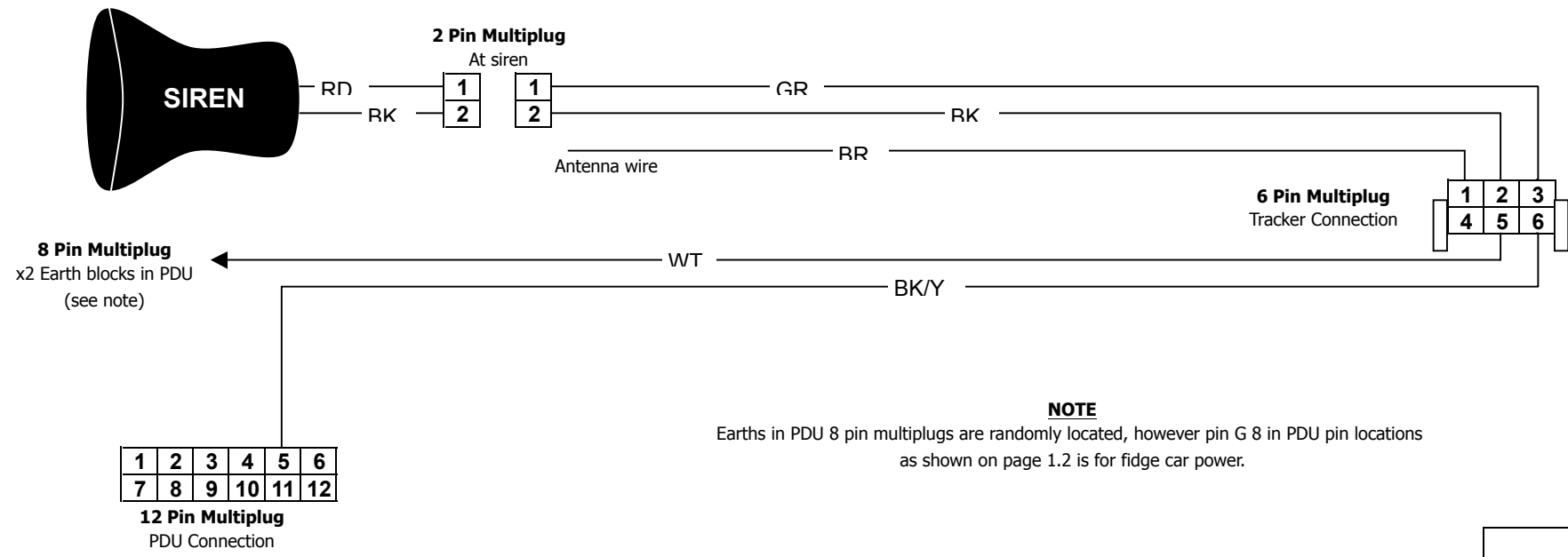

**NOTE**  
Earths in PDU 8 pin multiplugs are randomly located, however pin G 8 in PDU pin locations as shown on page 1.2 is for fridge car power.

Colour Codes

- RD - Red
- WT - White
- GR - Green
- BL - Blue
- BR - Brown
- BK - Black

Antenna wire has to be a minimum of 2.1 mtr's long & a verticle height of 45cms



# WIRING DIAGRAMS

Index Ref No: 2.3.0

## WATER PUMP

Nov-07

### Discovery / Ranger / Pageant 5

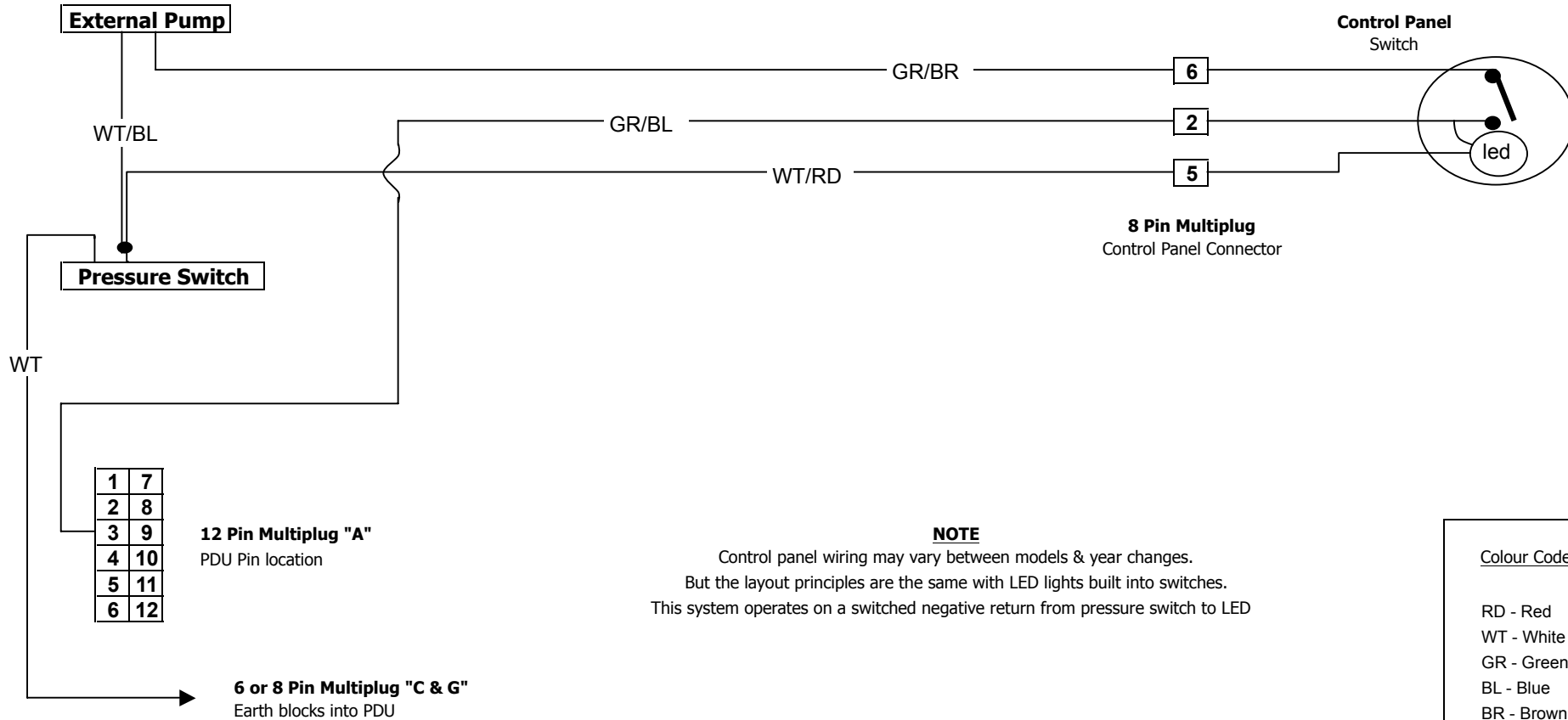

#### NOTE

Control panel wiring may vary between models & year changes.  
But the layout principles are the same with LED lights built into switches.  
This system operates on a switched negative return from pressure switch to LED

#### Colour Codes

RD - Red  
WT - White  
GR - Green  
BL - Blue  
BR - Brown  
BK - Black





# WIRING DIAGRAMS

Index Ref No: 2.3.1

## WATER PUMP Ranger 6 & GT60

Jun-08

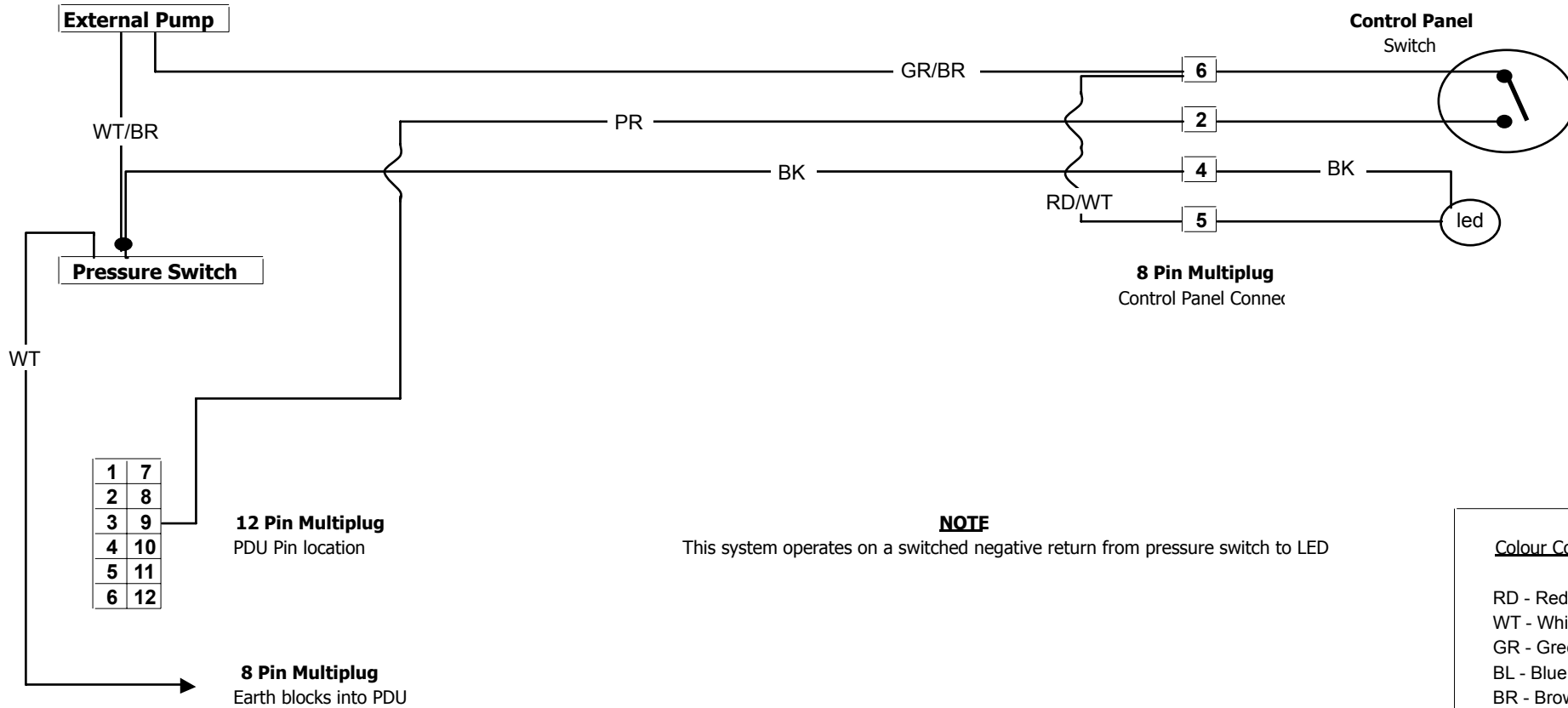

### NOTE

This system operates on a switched negative return from pressure switch to LED

### Colour Codes

RD - Red  
WT - White  
GR - Green  
BL - Blue  
BR - Brown  
BK - Black



# WIRING DIAGRAMS

Index Ref No: 2.4.0

## WATER PUMP Pageant 6

Dec-07

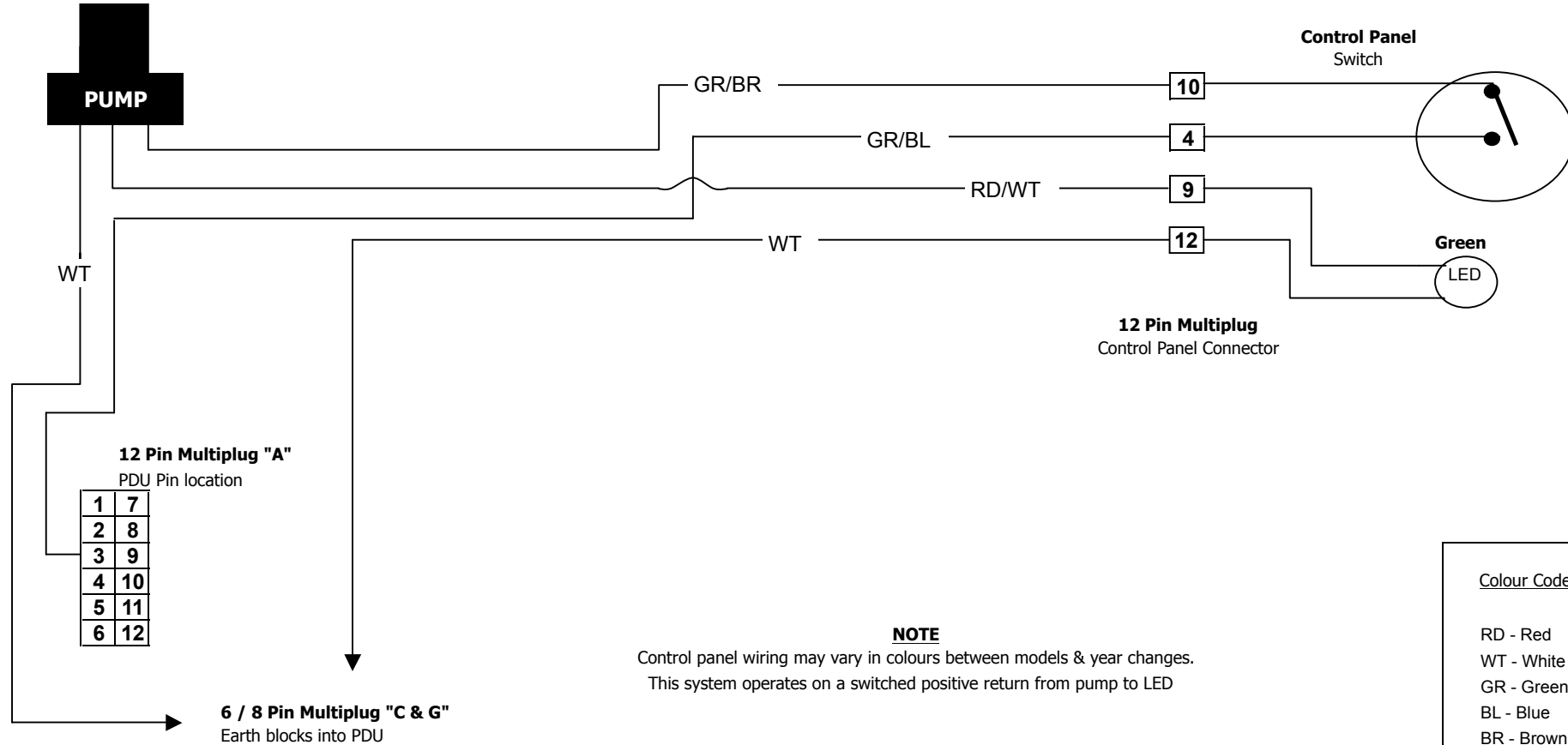

### NOTE

Control panel wiring may vary in colours between models & year changes.  
This system operates on a switched positive return from pump to LED

### Colour Codes

RD - Red  
WT - White  
GR - Green  
BL - Blue  
BR - Brown  
BK - Black



# WIRING DIAGRAMS

Index Ref No: 2.4.1

WATER PUMP

Jun-08

Pageant 7 Up to July 2008

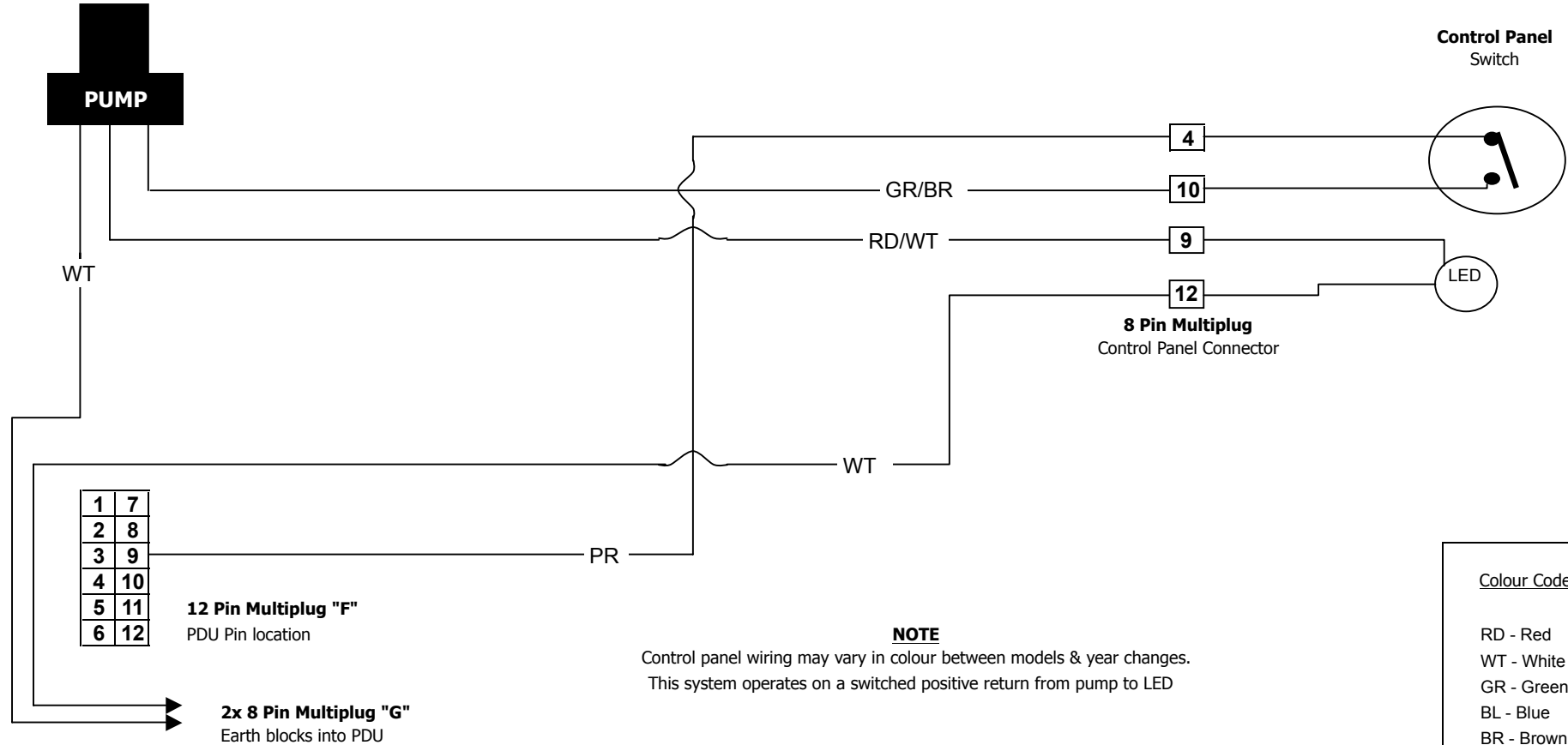



# WIRING DIAGRAMS

Index Ref No: 2.5.0

## WATER PUMP & TANK FLOAT Senator Series 5

Dec-07

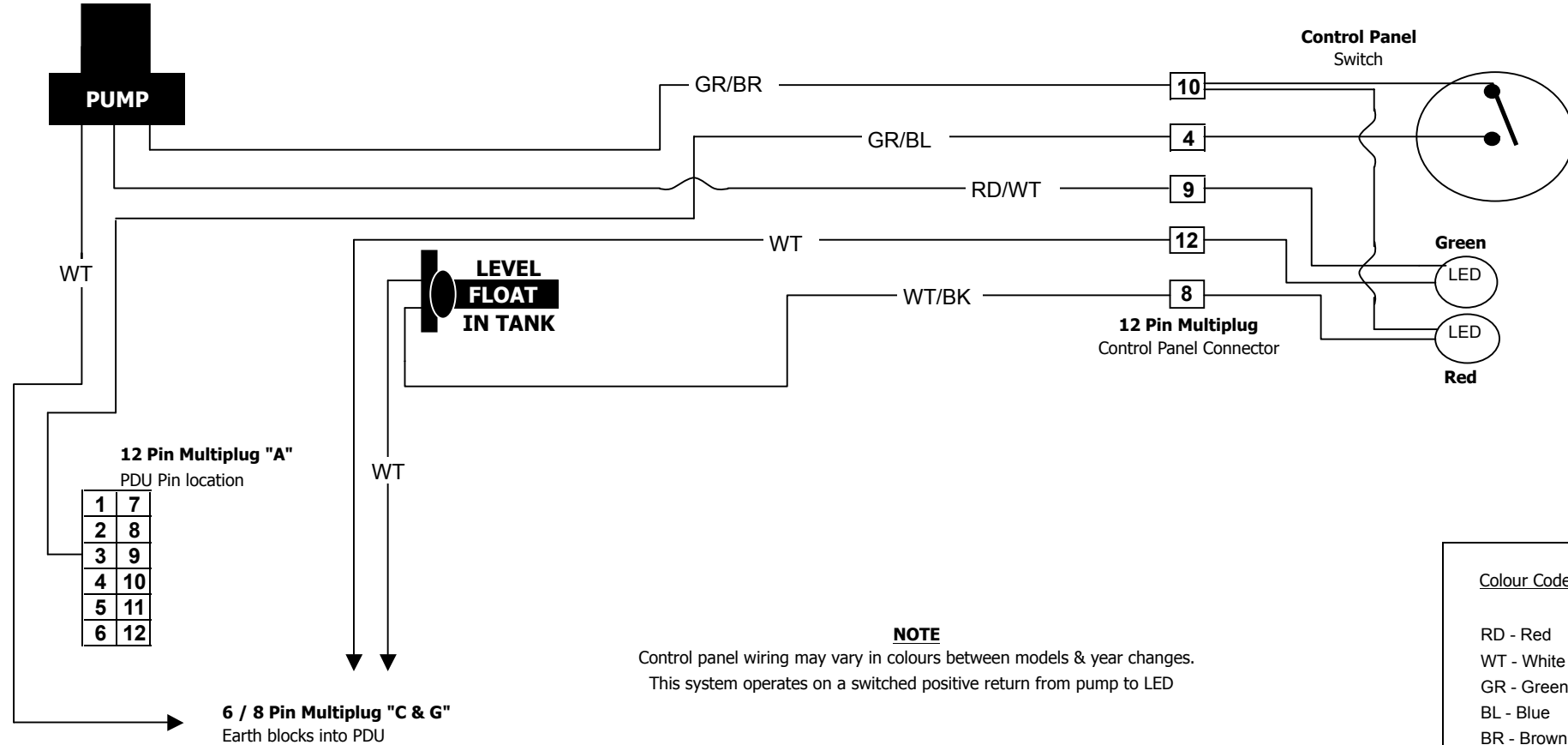



# WIRING DIAGRAMS

Index Ref No: 2.5.1

## WATER PUMP Senator 6

Dec-07

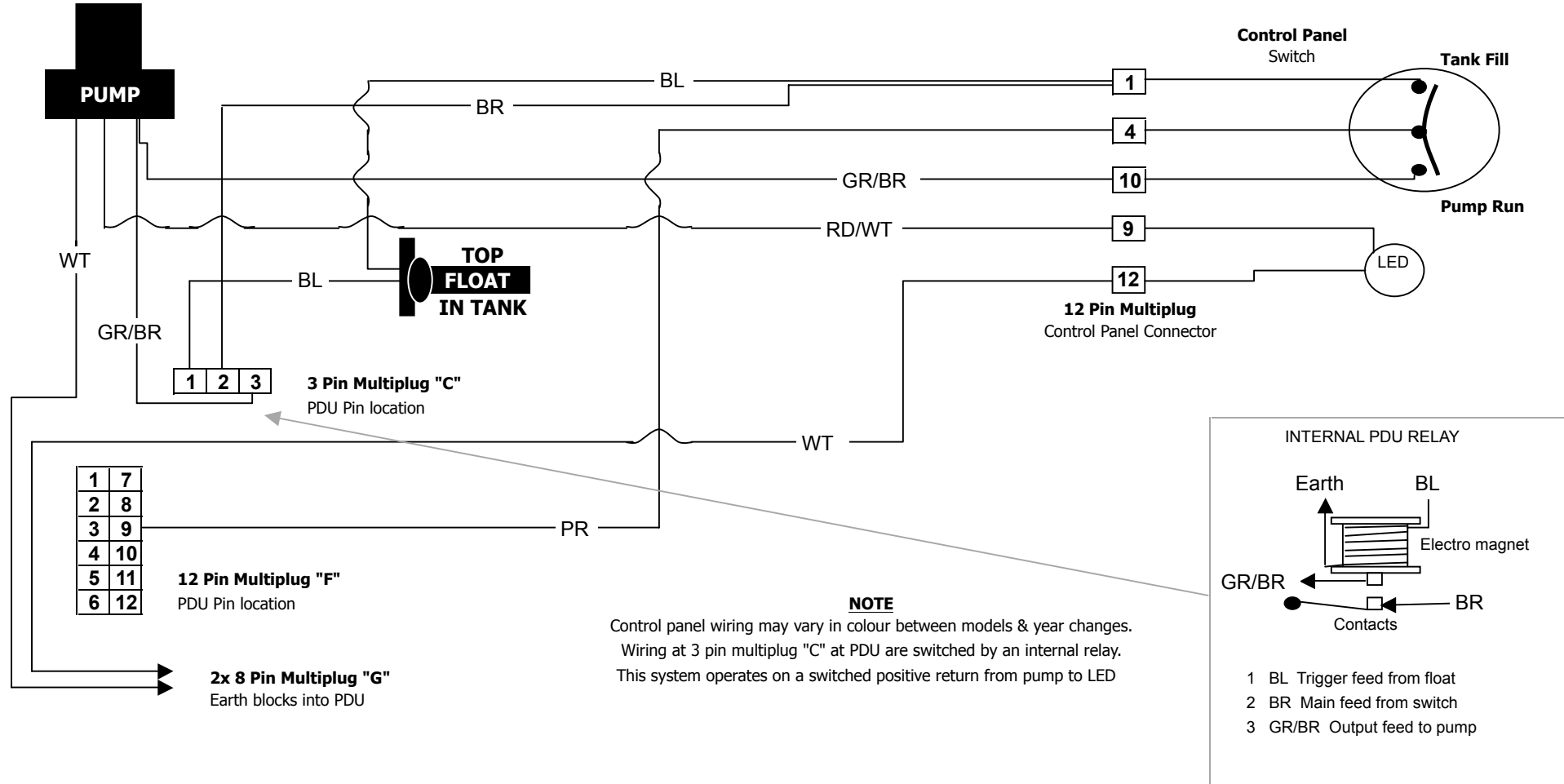

**NOTE**

Control panel wiring may vary in colour between models & year changes.  
Wiring at 3 pin multiplug "C" at PDU are switched by an internal relay.  
This system operates on a switched positive return from pump to LED



# WIRING DIAGRAMS

Index Ref No: 2.6.0

## APPLIANCES

Dec-07

### Discover / Ranger / Pageant / Senator 5

**NOTE**  
Some connectors may be crimped together & not multiplugged

**EARTHS!** Earths at PDU are randomly located into "C & G" connectors (multilinked internally)  
Pin "C 8" however is for car power only.

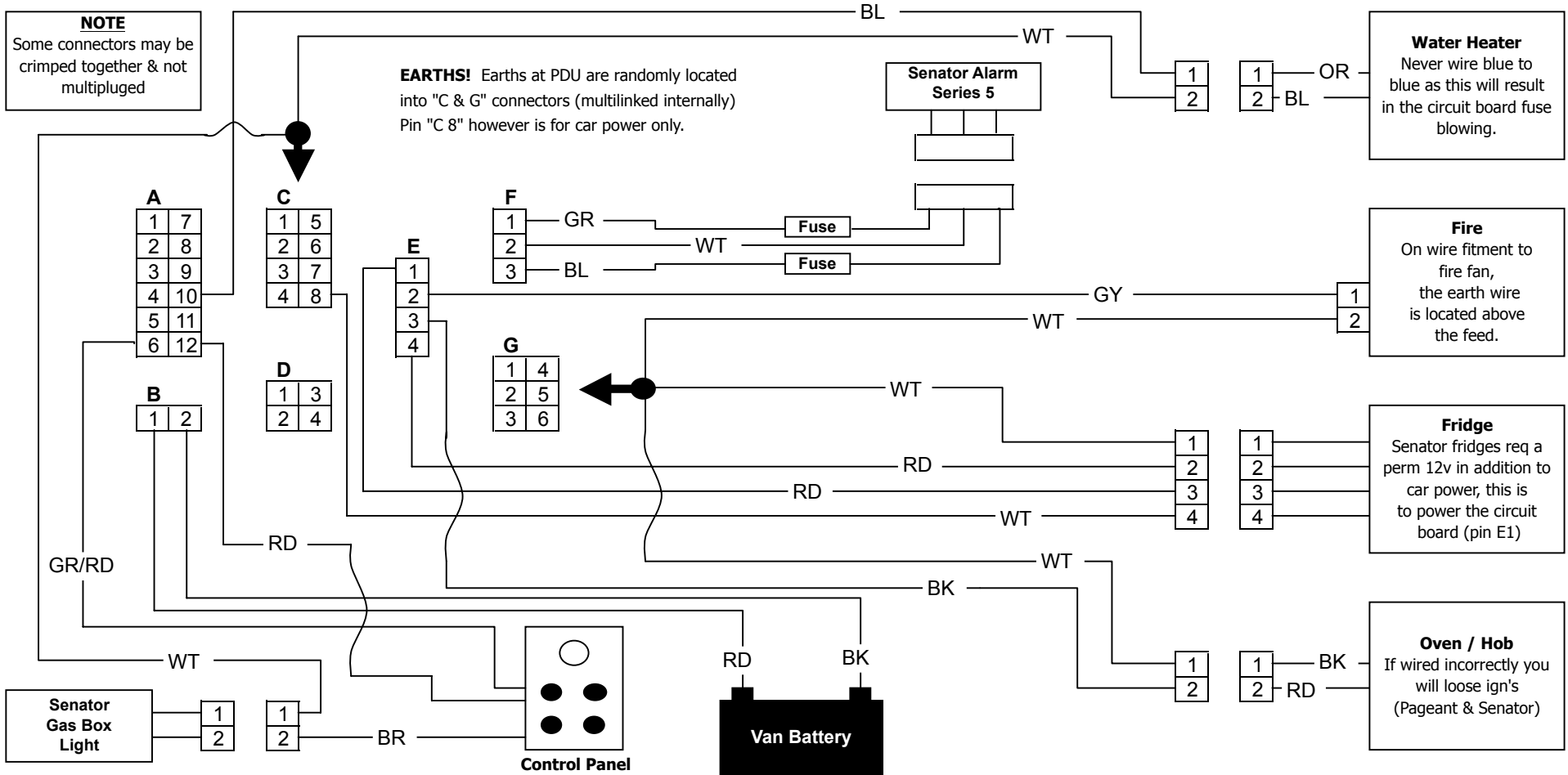



# WIRING DIAGRAMS

Index Ref No: 2.6.1

## APPLIANCES

Dec-07

### Senator 6

**NOTE**  
Some connectors may be crimped together & not multiplugged

**EARTHS!** Earths at PDU are randomly located into "G" connectors (multilinked internally)  
Pin "G 8" however is for car power only.

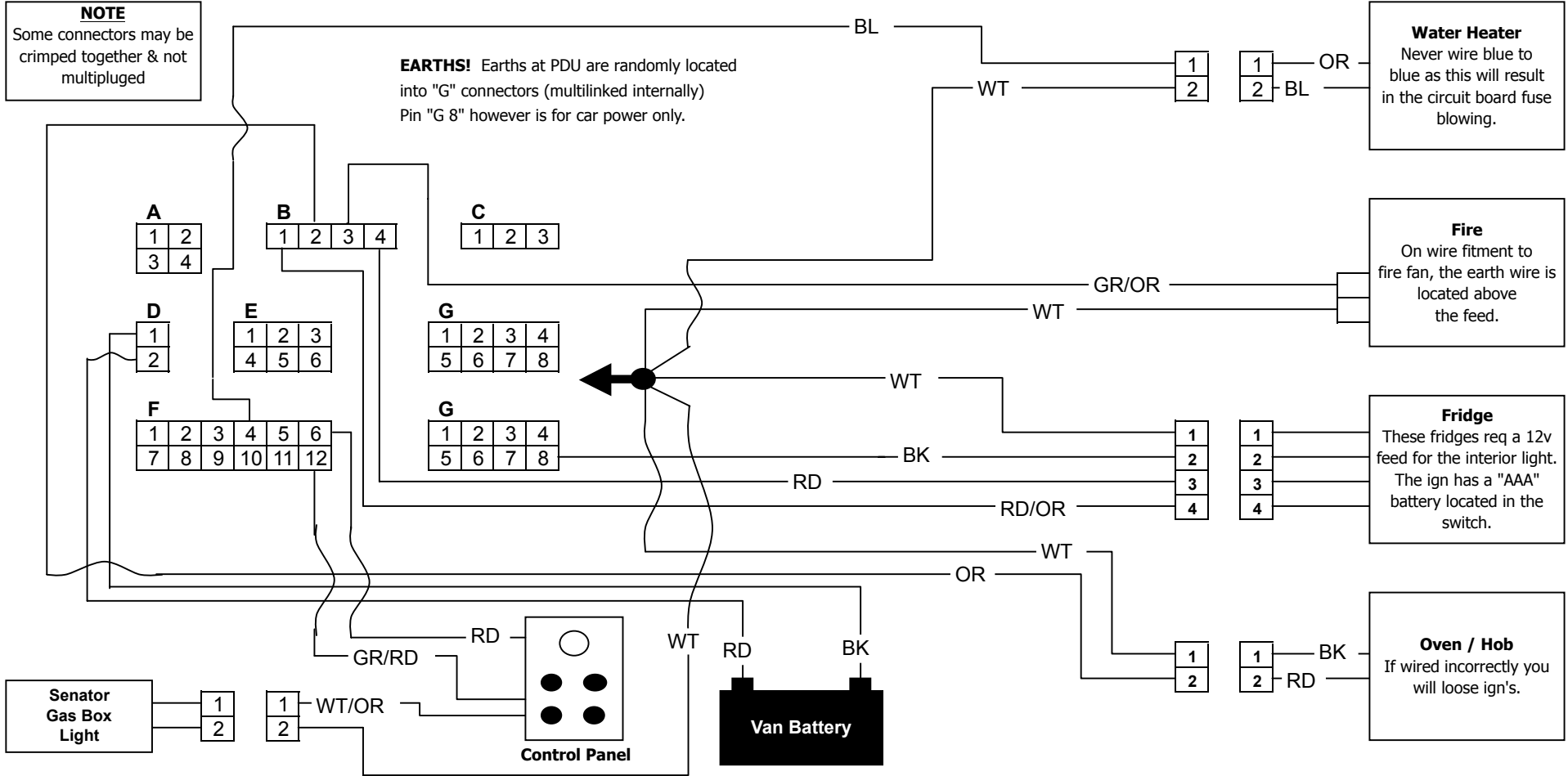



# WIRING DIAGRAMS

Index Ref No: 2.6.2

## APPLIANCES Ranger 6 & GT60

Jun-08

**NOTE**  
Some connectors may be crimped together & not multiplugged

**EARTHS!** Earths at PDU are randomly located into "G" connectors (multilinked internally)  
Pin "G 8" however is for car power only.

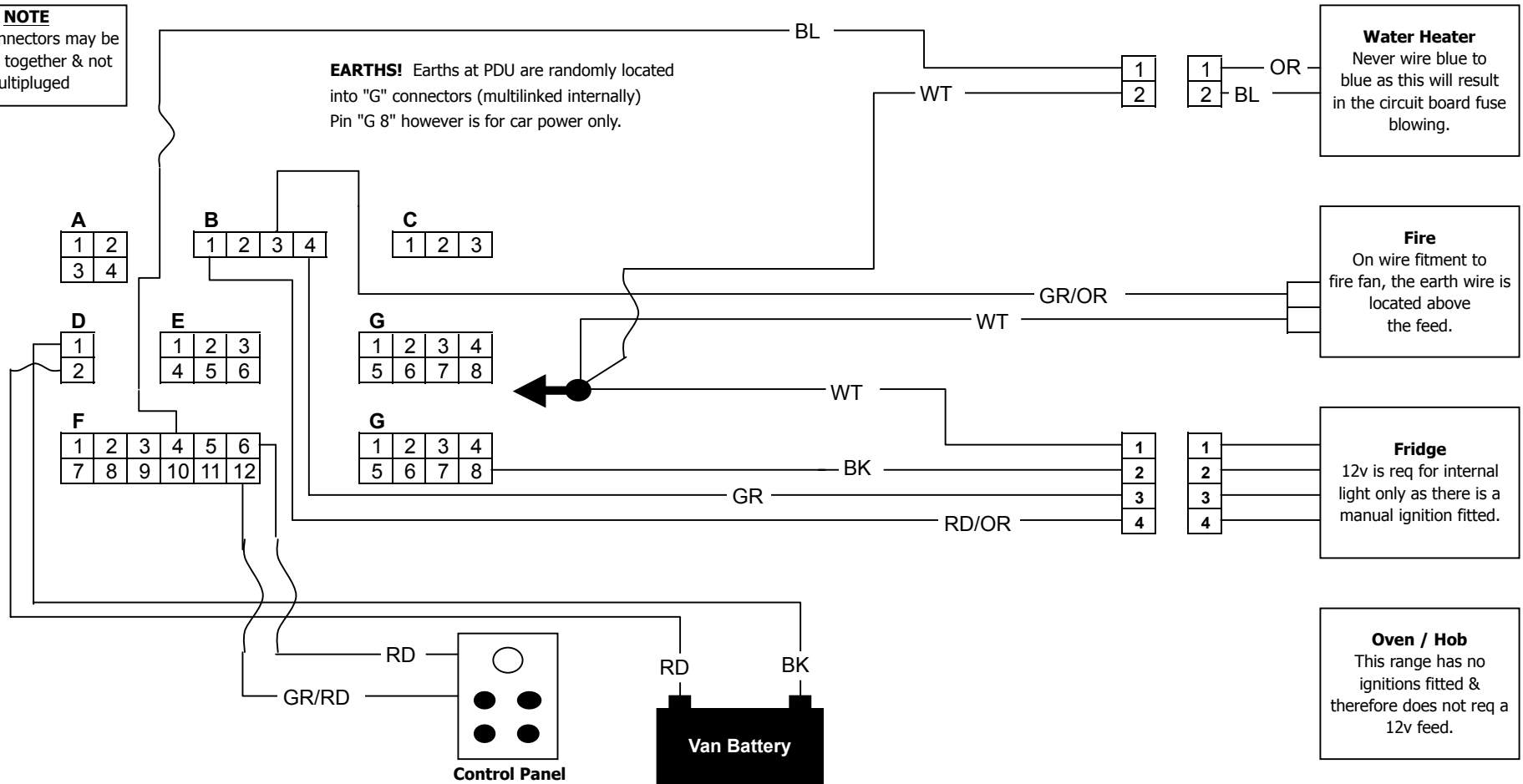





# WIRING DIAGRAMS

Index Ref No: 2.6.3

APPLIANCES

Jun-08

Pageant 7

**NOTE**  
Some connectors may be crimped together & not multiplugged

**EARTHS!** Earths at PDU are randomly located into "G" connectors (multilinked internally)  
Pin "G 8" however is for car power only.

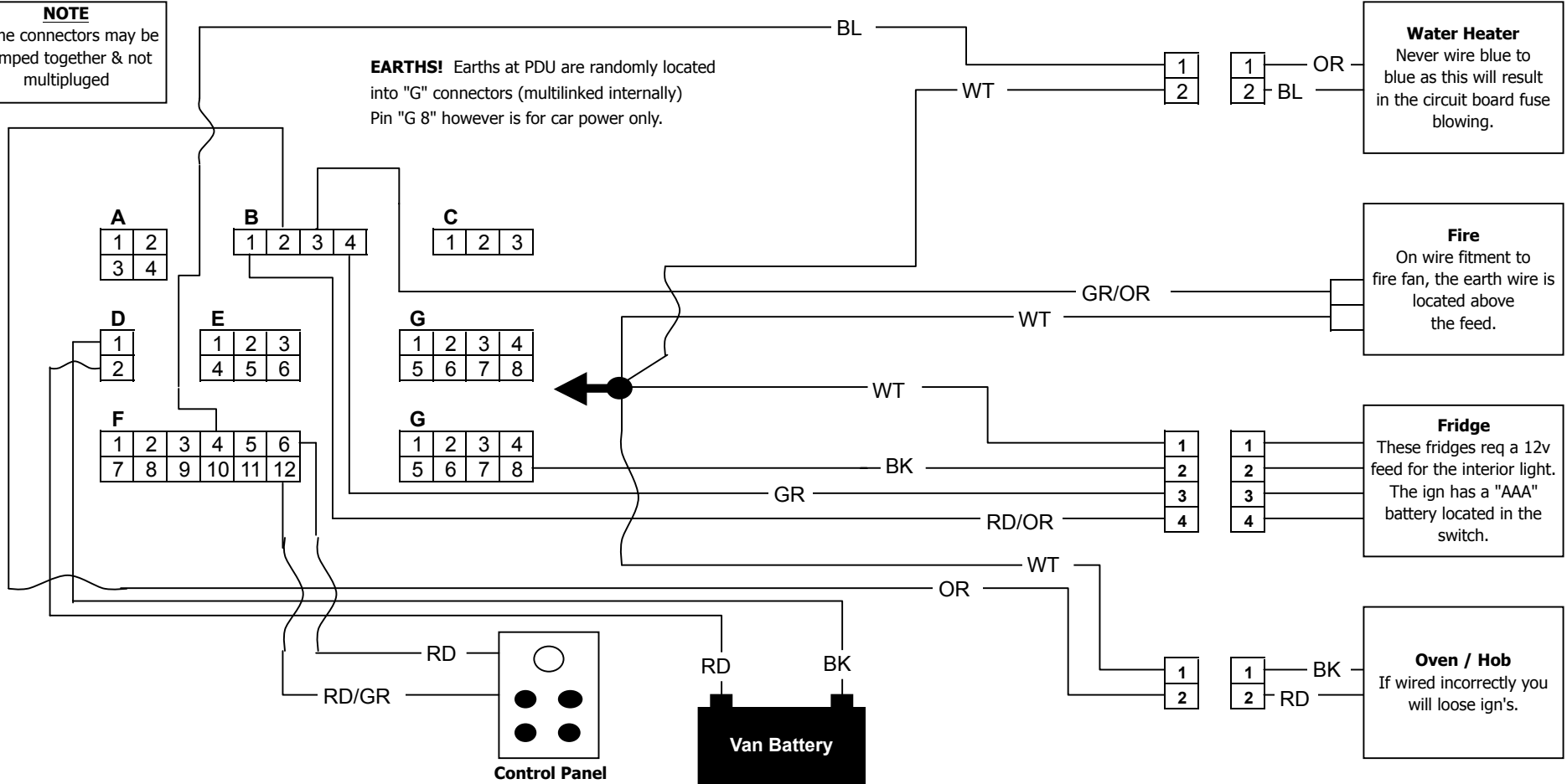



# WIRING DIAGRAMS

Index Ref No: 2.7.0

## Rear Road Lighting

Feb-08

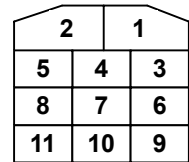

11 Pin connector  
from back panel

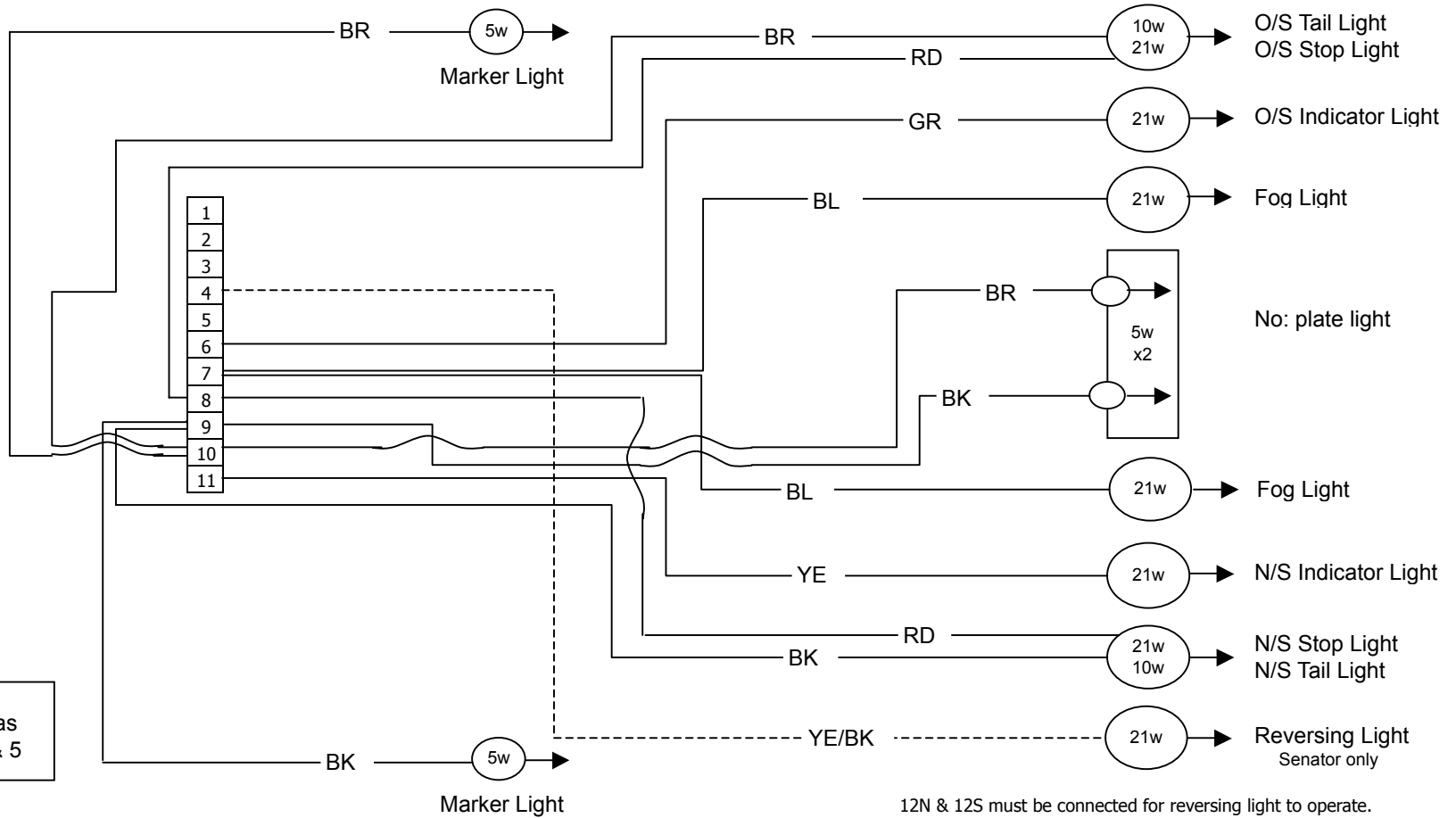

Note  
All arrows return back as  
earths to pins 1 / 2 / 3 & 5



# **INFORMATION & SETTINGS**

**INDEX**

# **3**



# INFO & SETTINGS

Index Ref: 3.1.0

PIR CODING INSTRUCTIONS

Dec 07

## Senator 6

### Code location:

The tracker has a identification code on installation, the last digit of this code is the code for your PIR setting.

### Setting the code:

1. Open the PIR housing by removing the locking screw at the base of the unit.
2. Take care not to lose the anti tamper spring or screw.
3. Locate the DIL switch & set each of the 9 switches to the appropriate code (as shown below).
4. Reassemble the PIR housing & fit locking screw.

### Testing the PIR:

1. Set alarm system by pressing key fob. (the system will chirp twice)
2. Allow system to arm, this will take approximately 60-90 seconds.  
NOTE Do not trigger PIR in set up time as this may prevent arming
3. Set off PIR by moving in front of the PIR sensor.
4. Press key fob to disarm the system. (the system will chirp once)

### CODE

0

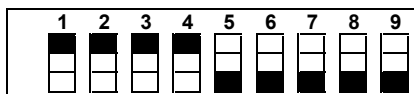

1

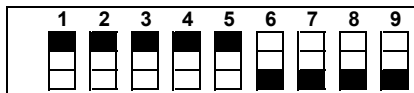

2

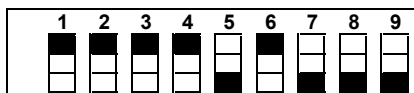

3

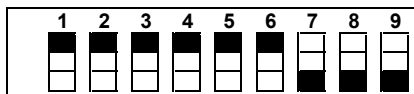

4

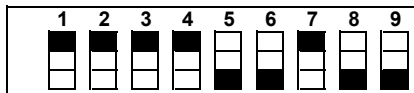

5

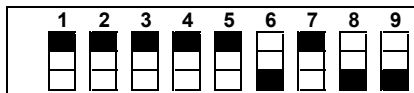

6

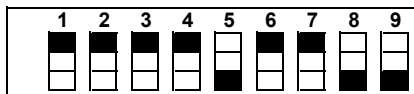

7

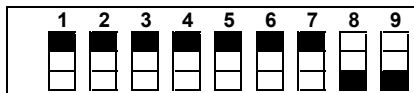

### CODE

8

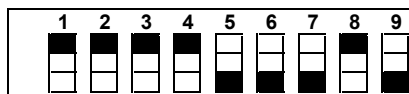

9

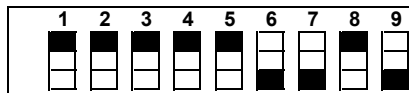

A

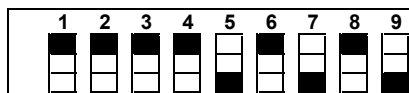

B

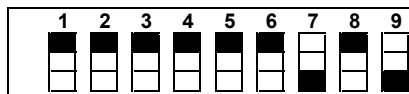

C

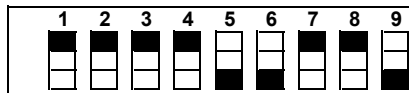

D

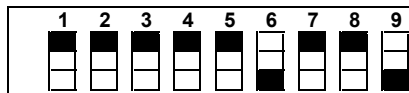

E

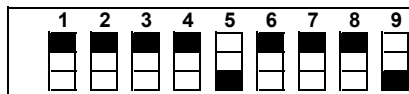

F

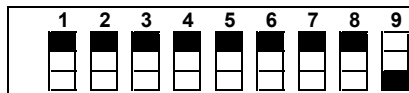



# INFO & SETTINGS

Index Ref: 3.2.0

ALARM FOB PROGRAMMING

Jan-08

## Senator 6

These alarm systems can have up to five remotes programmed at any one time. Before carrying on to the programming make sure you have your new remotes ready & they are in working order. (check the LED lights up on pressing the button) If your new remote does not light up try replacing the 12v internal battery.

Battery Part No: 1x Alkaline 23AE 12v

### **Adding new remotes using existing key fob**

- 1 Disarm the alarm by pressing the key fob button. (siren will beep once)
- 2 Within five seconds press the fob button once again (siren will beep twice)
- 3 Within five seconds press the fob button once again (siren will beep once)
- 4 Within five seconds press the fob button once again (siren will beep twice)
- 5 Within five seconds press the fob button once again (siren will beep once)
- 6 Within five seconds press the fob button once again (siren will beep twice)
- 7 Within five seconds press the fob button once again (siren will beep once)
- 8 On the seventh press of the fob the siren will beep three times
- 9 Within five seconds press the button three times on the **new** key fob which you wish to install.
- 10 On the third press the siren will beep twice & arm the alarm.
- 11 Disarm the alarm by pressing any of the key fob buttons.

### **Adding a new remote when all are lost**

- 1 This procedure will involve gaining access to the alarm control unit which is located on the tracker board.
- 2 Remove the blanking grommet in the face of the alarm control unit.
- 3 Press the button on the PCB three times within five seconds (siren will beep three times)
- 4 Press the button on the new remote three times, on the last press the siren will beep twice. The alarm is now armed, disarm the alarm to complete programming.



# INFO & SETTINGS

Index Ref: 3.3.0

ATC

Jan-08

AL-KO Trailer Control or ATC as it's known is an electrical actuator fitted into the braking system, the purpose of this unit is to prevent trailer "sway".  
The system only req's live & earth feeds from the vehicle's 12s connection.

## **Testing**

On connecting the power source the LED indicator will show red and pass through a self test, once the unit has cleared it's test the LED will turn to green.  
If for any reason you enter a second test straight away the LED may **flash** green, this is also a system pass & will reset its self once in motion.

## **LED Not Illuminating**

In the event of no illumination certain checks need to be made.

- 1 Check car power is ok. (12S connector) i.e.; closed up pins.
- 2 Power at 14 pin connector at actuator.
- 3 Wiring ok up to LED light.

## **Red LED After Self Test**

This will indicate a fault within the system. Before investigation is carried out, retest the system once again to confirm fault exists. Leave disconnected for approximately five seconds in-between testing.  
If the LED is still indicating red it's recommend that the unit's memory be read by a AL-KO engineer.



# **DIAGNOSTICS & TROUBLESHOOTING**

**INDEX**

# **4**



# DIAGNOSTICS & TROUBLESHOOTING

Index Ref No: 4.1.0

## No 12v Power On Van

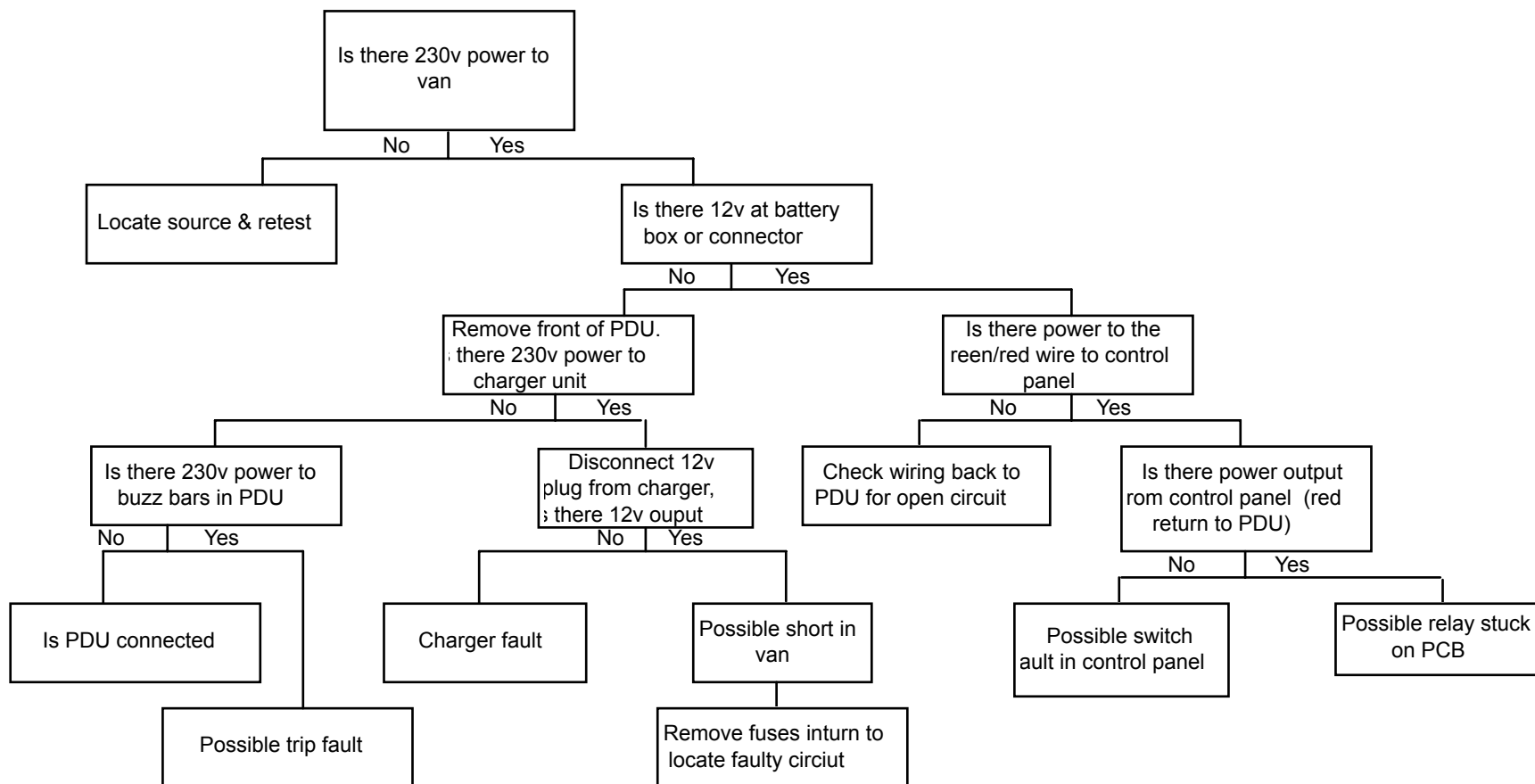





# DIAGNOSTICS & TROUBLESHOOTING

Index Ref No: 4.2.0

## ULTRA STORE DIAGNOSTIC FLOW CHART

Nov-07

### All Ranges

Waterheater fault reported, confirm fault exists.  
Is there an audible click from waterheater.

230v ultastore Test Readings

Dial Settings  
Switch on

Pulling Amps  
5 amps

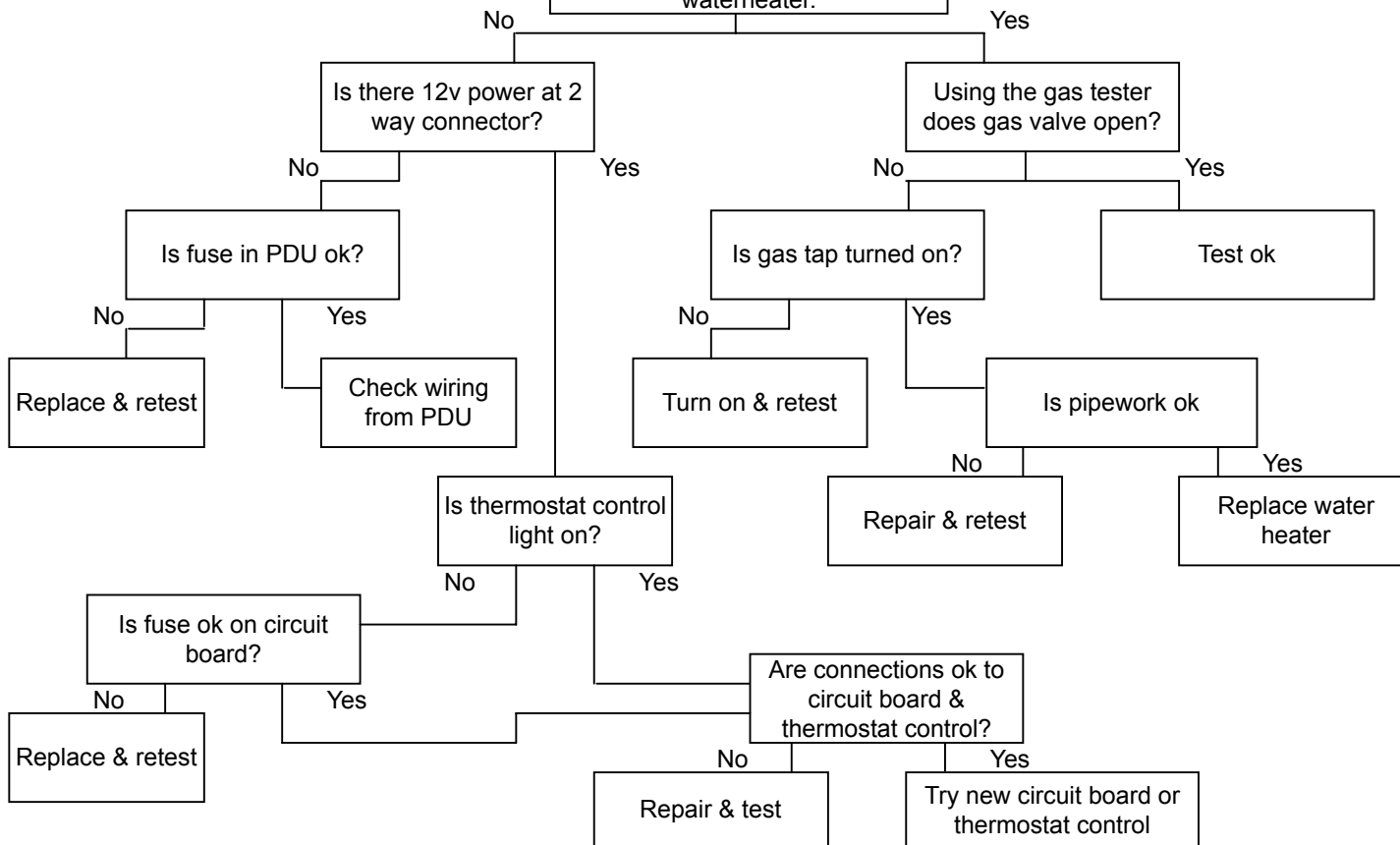



# DIAGNOSTICS & TROUBLESHOOTING

Index Ref No: 4.1.0

## ULTRA HEAT DIAGNOSTIC FLOW CHART

Nov-07

### All Ranges

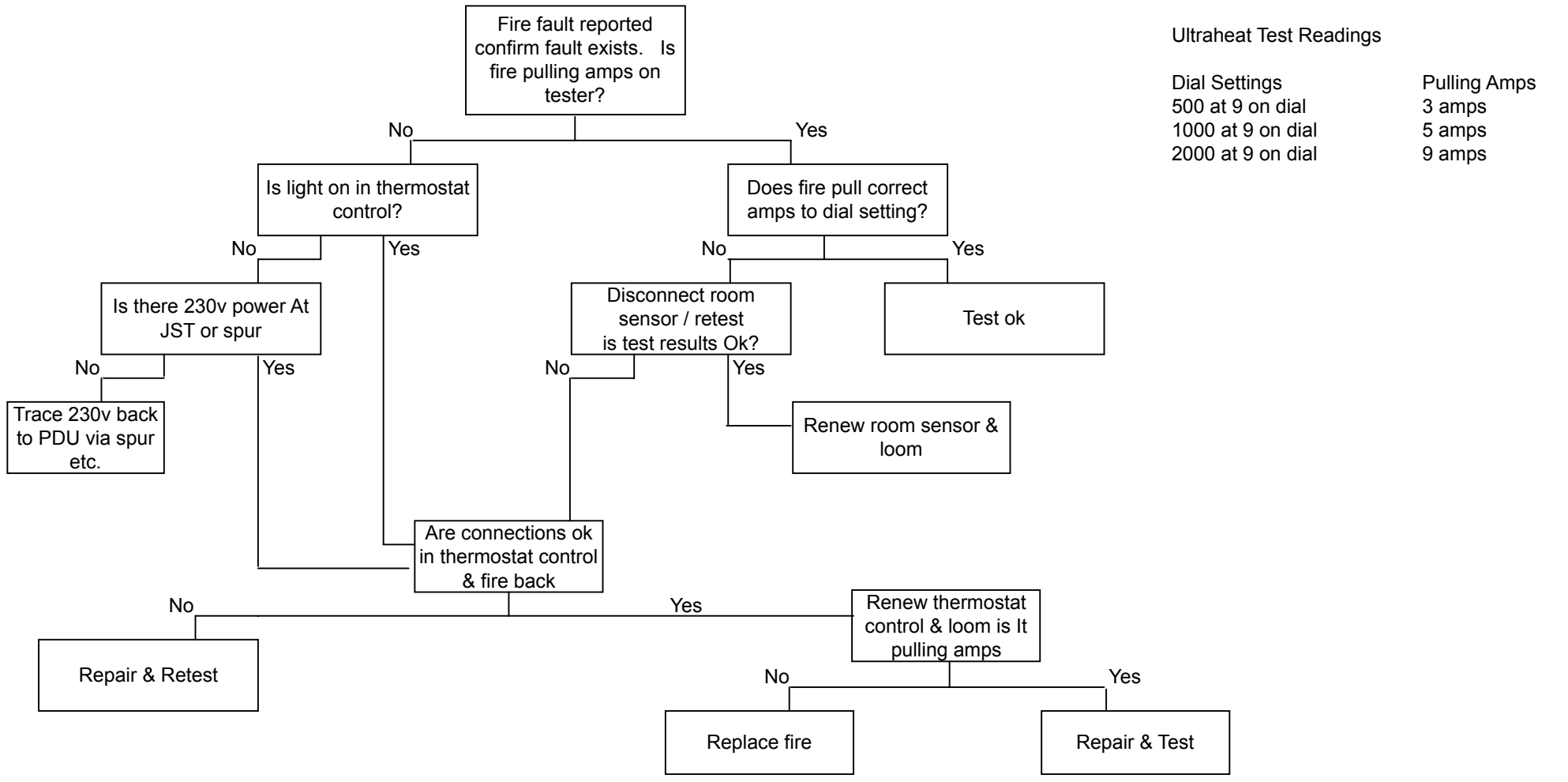











# TROUBLESHOOTING

Index Ref No: 4.7.0

ATC

Jun-08

## AL-KO ATC LED Conditions

Display	Status	Consequence	Self Help	Display After Self Help	Status
Constant Green Light	ATC Active	Everything OK			
Green Flashing Light	ATC Active, Self test not concluded	Possible to continue journey	Move car & caravan forward a few metres to enable the sensor to detect movement	Becomes green (constant plus)	Possible to continue journey
				Stays flashing green	ATC faulty, possible to continue journey. Consult a specialist workshop
Constant Red Light	ATC Inactive	Possible to continue journey	Remove 13 pole / 12S trailer cable on the towing vehicle. Wait approx. Five seconds. Insert 13 pole / 12S trailer cable on the towing vehicle.	Becomes green (constant plus)	Possible to continue journey
				Stays constant red	ATC faulty, possible to continue journey. Consult a specialist workshop
Red Flashing Light	ATC Brakes	Carrying on journey is prohibited	Remove 13 pole / 12S trailer cable on the towing vehicle. Wait approx. Five seconds. Insert 13 pole / 12S trailer cable on the towing vehicle.	Becomes green (constant plus)	Possible to continue journey
				Stays flashing red	ATC Faulty - not possible to continue driving Remove ATC push rod Consult a specialist workshop
Led Not Alight	ATC has no power	Only drive on after checking the status!	Check if constant plus available  Remove 13 pole / 12S trailer cable on the towing vehicle. Wait approx. Five seconds. Insert 13 pole / 12S trailer cable on the towing vehicle.	Becomes green (constant plus)	Possible to continue journey
	LED Faulty			LED not alight	If power supply OK → carry out visual inspection, see instruction manual Consult specialist workshop

This page has been published by AL-KO themselves, please use at your discretion as the specialist repairer may be you!



# DEALER FEED BACK

The information received by the Dealer Feed Back Scheme is a vital source of information that can be used by our team of production engineers, Bailey is always looking for ways of improve it's product. It can also be used by you the dealer as a network for workshops to communicate, in turn helping us to prevent future problems & allowing us together to provide a trouble free experience for the customer.

If you wish to participate in Dealer Feed Back & Troubleshooting, Please E-mail the following details below to

[Iant@Bailey-Caravans.co.uk](mailto:Iant@Bailey-Caravans.co.uk)

REPORT SHEET LAYOUT
Company Name Technicians Name Contact No:
_____
Van Model & Year
_____
Fault Description
_____
Fault Rectification Report
_____
Parts Used (if any)
_____
Your Comments
_____